

## Low Profile Deck 7000 mm, with Extension Coupling, Over-rideable

170 t

### Datasheet:

- Flat box-type design from high-tensile steel StE 690
- Through steel flooring on the whole loading area
- In front claw coupling for connection to a universal gooseneck or to a quick-coupling adapter, at rear coupling head for modular bogie
- Hydraulic, brake and electric lines installed within the frame, with couplings
- 1 pair lashing rings LC 30000 daN on the rear coupling head  
2 pairs bushings for screw-in lashing rings LC 20000 daN laterally of the rear coupling head  
7 pairs bushings for screw-in lashing rings LC 20000 daN laterally in the outer frame  
7 pairs bushings for screw-in lashing rings LC 20000 daN on top of the outer frame including 4 units screw-in lashing rings LC 20000 daN
- Deadweight including quick-coupling adapter approx. 15600 kg

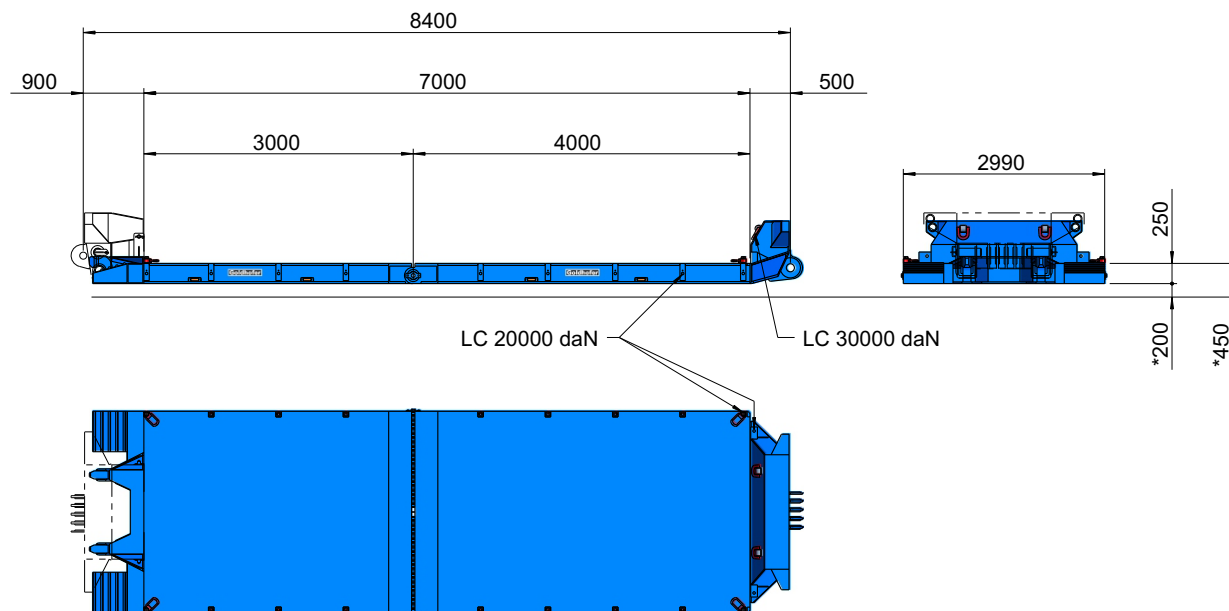
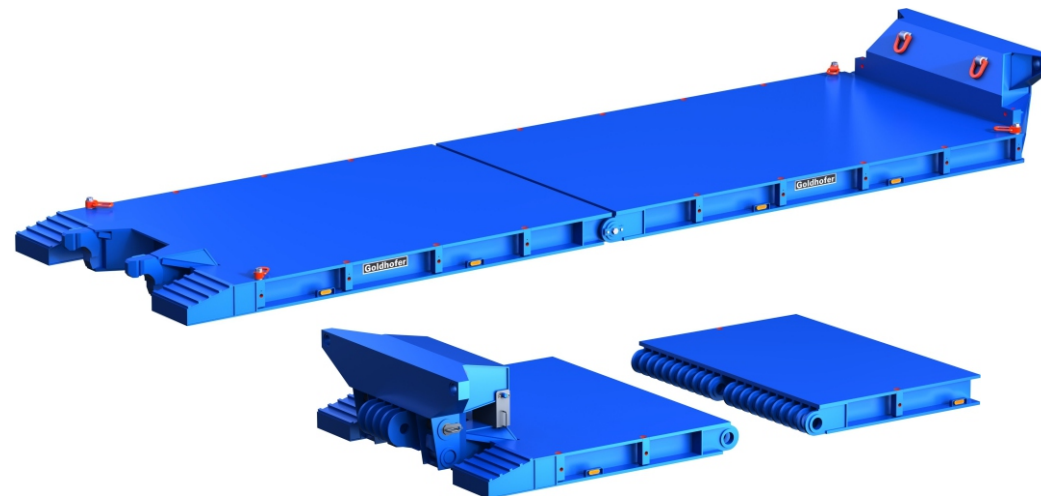

### Options

Quick-coupling adapter	1600 kg
Side extensions incl. insert elements	600 kg
Extension 3000 mm	5000 kg
Extension 4000 mm	6200 kg
Extension 5000 mm	7500 kg

Payload	209 t	172 t	146 t
In trailer combination	5+5	6+6	7+7
Payload	161 t	139 t	122 t
In semitrailer combination	4+6	5+7	6+8

Remark: The given payloads are solely technical values.  
They do not form a statement on legally permissible payloads.  
Illustration similar, drawing not to scale.